

Melec



AL- Series PCI Express Master

AL2-04/PCIE

Instructions Manual (For designers' use)

USER'S MANUAL

Please ensure to read and understand this Instructions Manual before using the Product. Please keep this Instructions Manual at hand so that it is always available for reference.

MN0217

Introduction

This instructions manual explains the handling of "AL- Series PCI Express Master AL2-04/PCIE", emphasizing the specifications to enable proper and safe use.

The manual is thus intended for designers of control systems using servo motors and stepping motors. Before using the product, read this manual carefully for better understanding.

Keep the manual handy so that you can read it whenever you want.

Wish on a safety design

The product and product specification which are indicated in this manual may be changed without a preliminary announcement by improvement etc.

The technical information indicated in this manual is for explaining typical operation and application of a product, and does not perform consent of the guarantee to the intellectual property rights and other rights of our company and a third party, or an actual right on the occasion of the use.

When you use the circuit indicated in this manual, software, and the information relevant to these, please fully evaluate by a user's whole apparatus and system.

Moreover, please judge application propriety on a user's responsibility.

The product which uses a semiconductor and a semiconductor may malfunction depending on an operating condition, or a certain probability.

In order not to generate an accident resulting in injury or death, a fire accident, social damage, etc. by failure or malfunction of this product, please cope with a safety design required for the last equipment or a system, according to a user's responsibility.

This product is designed and manufactured as a general industrial-oriented general-purpose product.

Therefore, please do not use aircraft instruments, an aerospace instrument, a submarine relay appliance, a nuclear control system, transport plane machines (vehicles, a vessel, etc.), the signal machine for traffic, disaster prevention / crime prevention apparatus, a safeguard, medical equipment, etc. for the use which can consider big influence by a human life or property.

Do not carry out reconstruction, change, and reproduction of this product.

Please observe export related statutes applied, such as "foreign exchange and Foreign Trade Law", when exporting, and perform required procedure by the place provided by this statute.

Please do not use the technical information indicated in this product or this manual for the purposes, such as development of mass-destruction weapons, the purpose of military use, and the other purpose of a military use.

Moreover, this product cannot be used for the apparatus to which manufacture, use, and sale are forbidden by a statute in and outside the country and regulation.

Please be sure to ask to window of our marketing department about details, such as the environmental suitability of this product.

When using it, content of a specific substance, RoHS Directive which regulates use, etc. should investigate the environmental related statute applied enough. And please suit this statute.

About the damage which arose by not observing the statute which requires to user, our company does not take any responsibility.

Description of safety

This product must be handled correctly.

Handling the product incorrectly may cause unexpected accidents resulting in personal injuries or damage to your properties.

Many of those accidents can be avoided if you have advance information on dangerous situations.

This manual provides precautions where dangerous situations are predicted. The manual provides the following alert marking and messages for this purpose:



This indicates a hazardous situation that could result in death or serious personal injury if you do not perform the procedure correctly.



This indicates a potentially hazardous situation that could result in personal injury or physical damage if you do not perform the procedure correctly.

Before use

Set up the product before operating it.

Please refer to the Section 3, "Setting."

Please refer to separate manual "AL- series device driver manual for Windows" also when you handle this product.

Introduction
 Wish on a safy design
 Description of safety
 Before use

| | Contents | PAGE |
|---|----------|------|
| 1 . Overview | | |
| 1-1. Features | ----- | 5 |
| 1-2. Product configuration | ----- | 6 |
| 1-3. Example of system configuration | ----- | 6 |
| 1-4. Function block diagram | ----- | 7 |
| 1-5. Externals of product | ----- | 8 |
| 2 . Specifications | | |
| 2-1. General specifications | ----- | 9 |
| 2-2. PCI specifications | ----- | 9 |
| 2-3. Communication specifications | ----- | 9 |
| 2-4. Master specifications | ----- | 10 |
| 2-5. Input and output signal table | ----- | 11 |
| (1) Serial communication connector(J1) | ----- | 11 |
| (2) USB communication connector(J2) | ----- | 11 |
| 2-6. Outside dimensions | ----- | 12 |
| 3 . Setting | | |
| 3-1. Setting of board number (S1) | ----- | 13 |
| 3-2. Setting of AL- communication | ----- | 13 |
| (1) Address setting of the AL- communication | ----- | 13 |
| (2) Baud rate setting of the AL- communication | ----- | 13 |
| 3-3. Setting of Extend-unit communication | ----- | 13 |
| 4 . Connection | | |
| 4-1. Connection of AL- communication system | ----- | 14 |
| (1) Core connection of AL- communications cable | ----- | 14 |
| (2) Connection of terminator | ----- | 14 |
| (3) Wiring distance of AL- communication | ----- | 14 |
| (4) Power supply and slave power supply for communication | ----- | 14 |
| 5 . OFFLINE | | |
| 5-1. Support environment of OFFLINE | ----- | 15 |
| 5-2. OFFLINE specification | ----- | 15 |
| 6 . Maintenance | | |
| 6-1. Maintenance and inspection | ----- | 17 |
| (1) Cleaning method | ----- | 17 |
| (2) Inspection method | ----- | 17 |
| (3) Replacement method | ----- | 17 |
| 6-2. Saving and disposal | ----- | 17 |
| (1) Saving method | ----- | 17 |
| (2) Disposal method | ----- | 17 |

The main parts which revised by this manual

1 . Overview

1-1. Features

The AL- series is a high speed serial communication system of original controlling the flexible stepping motor, servo motor which can cope easily as well and I/O in the decentralization of the device and supporting axial addition.

- The AL- series is an insulation type high-speed serial communications of 20 Mbps/50 m or 10 Mbps/100 m. As a result, the saving wiring for the personal computer system can be attempted by the performance (ratio of our company) that equals a board controller so far.
- The shift of board controller C-VX870 series (Device-function) for PCI made of our company and the USB series (Device-function and Unit-function) is easy depending on the device driver function for Windows.

The status of four axis batch reading and the command of four axis batch execution by the Unit-function became possible. This Unit-function can perform a unit and AL- interface by one function execution from an application. By this,

- The time crunch can be done compared with accessed Device-function of each axis and I/O-function of each I/O port.
- The Unit-function (writing) suppresses the difference at time until it instructs time each axis and each I/O output signal.
- The Unit-function can reduce the load of the application.
- It supports the Device-function, and can use the Device-function.
- The Unit-function can be used together with the Device-function and the I/O-function.

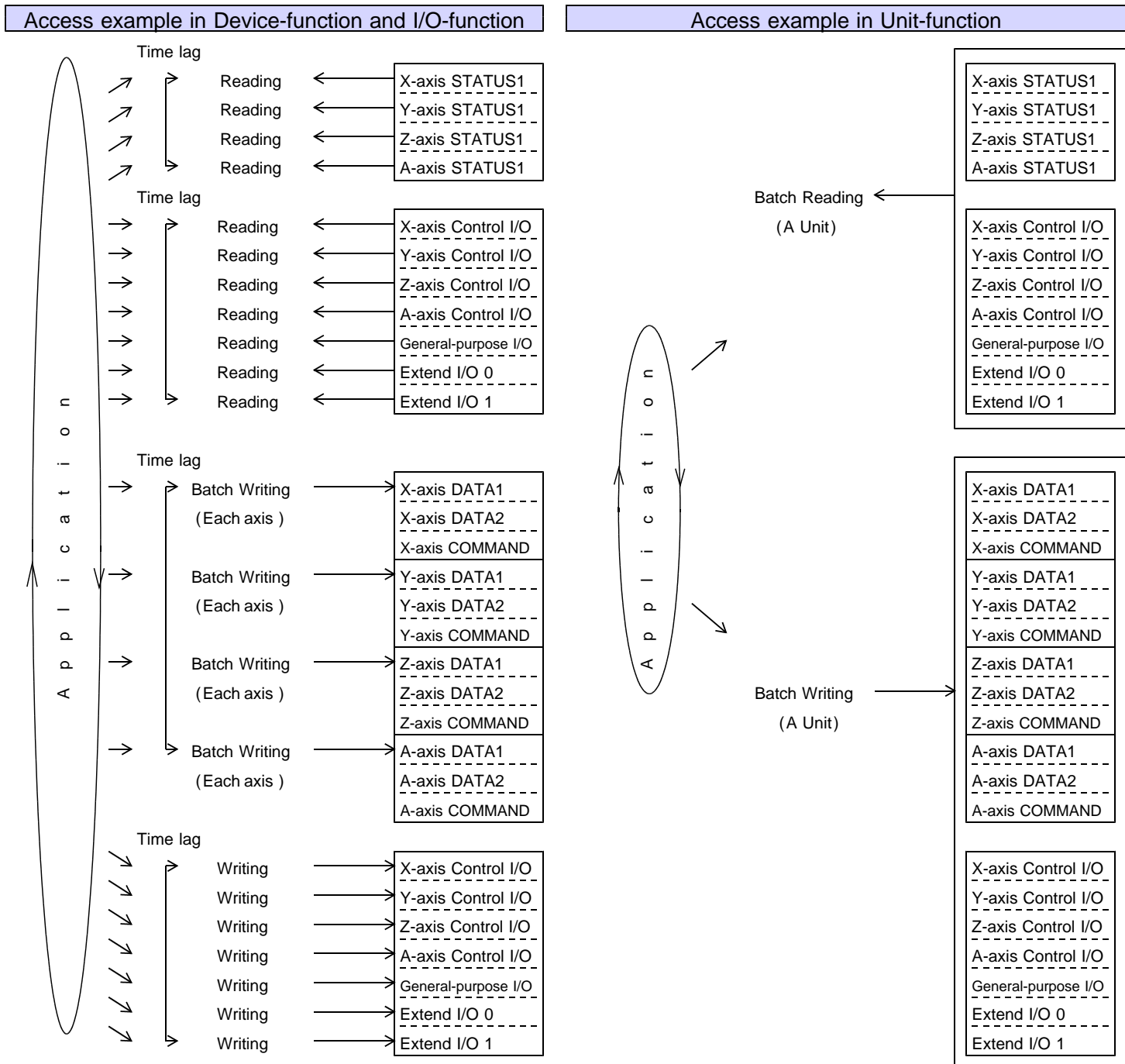

AL2-04/PCIE is a master for the AL- series that can do the direct insertion to the slot of PCI Express. The user controls the motor controller and I/O etc. of the AL- series by this master.

- It conforms to PCI Express specification R1.0a.
- The shape is standard height, half length card size (164.55 mm × 68.9 mm) of a PCI Express CEM standard (x1 Lane).
- Confirming the operation of each axis of each slave unit and the I/O signal can do immediately without the user program by the USB off-line application software that our company offers. Moreover, the master can back up the setting data of each slave unit. The setting data that this master backs up can transmit each slave automatically when the Initial-data-transfer-function is executed. Also, it is possible to overwrite data from the user application.

1-2. Product configuration

| Product name | Rating | Maker | Quantity | Remarks |
|--------------|-------------|------------|----------|-----------------------------|
| PCI Master | AL2-04/PCIE | Melec Inc. | 1 | For PCI Express (Main Unit) |

1-3. Example of system configuration

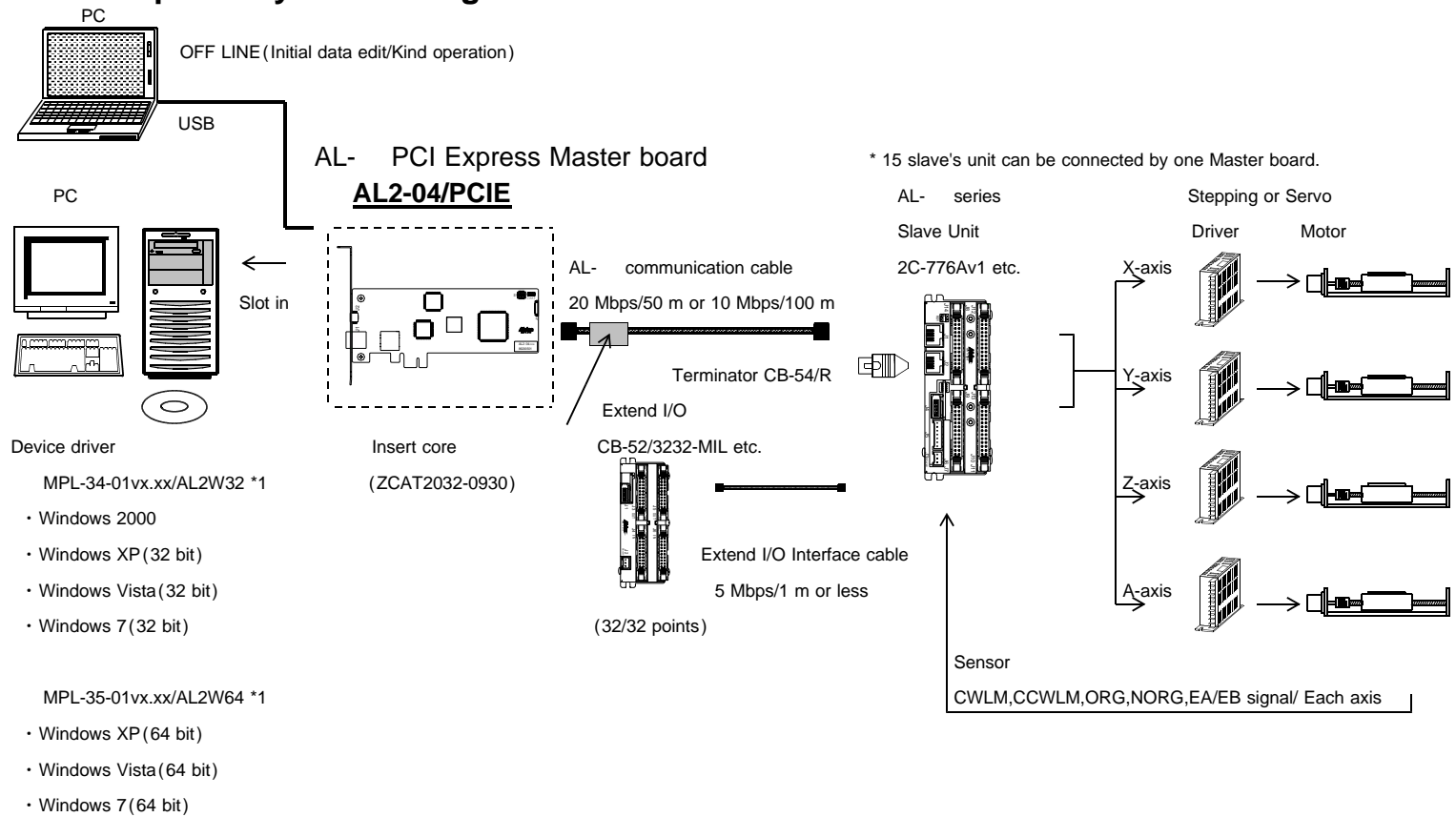

*1 Version No. ... Please confirm the latest version of vx.xx at the manual of the device driver.

- AL- series prepared connectable cables easily. Please refer to the "connection / others" instruction manual for details of connection of the AL- series.

Example of other AL- series

| Power supply relay board | Controller | Controller with built-in driver | | General-purpose I/O (Extend type and Slave type) | | |
|---|---|--|---|---|---|---|
| CB-55-01/PS-T35 • 4-distribution output of DC 24 V • 1 A/terminal (3.5 A in total) | 2C-771v1 • 4-axes • For stepping or simple servo | 2CD-7710v1/ADB5F30 • 2-axes for 5-phase stepping motor • 0.75 A/phase | 2CD-7713v1/GDB5F40 • 2-axes for 5-phase stepping motor • 1.4 A/phase | CB-53/1616-MIL • Extend type • In: 16-points • Out: 16-points | 2CB-01v1/3232-MIL • Slave type • In: 32-points • Out: 32-points | 2CB-02v1/1616-MIL • Slave type • In: 16-points • Out: 16-points |

1-4. Function block diagram

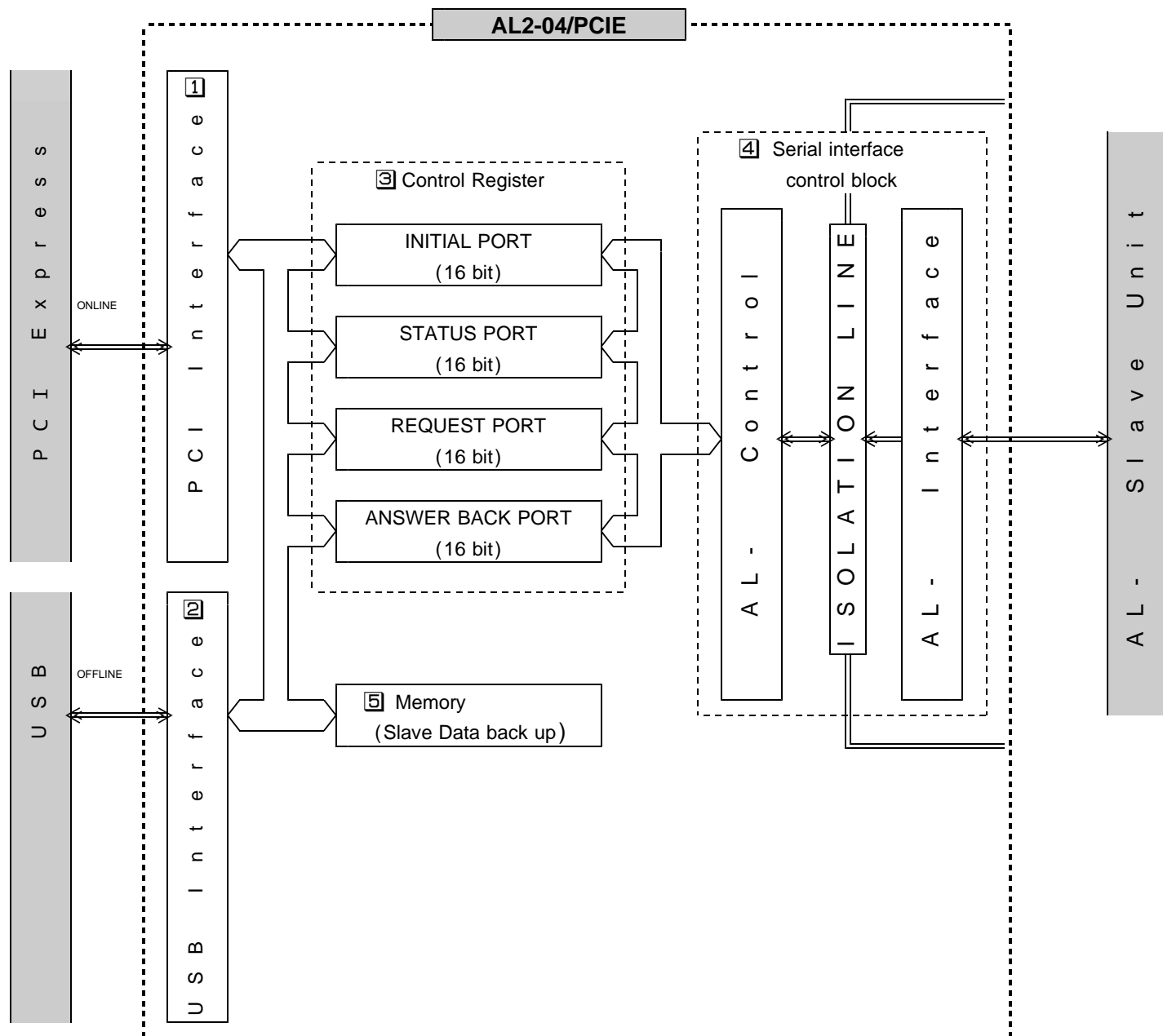

1 ONLINE (PCI Express) interface part
 This is an interface block with PCI Express.

2 OFFLINE (USB) interface part
 This is an interface block with USB.
 Setting and easy operation of each slave can be done by the application software for initialization.
 * ONLINE and OFFLINE cannot be controlled at the same time.
 Execute it after stopping the application from ONLINE when you control from OFFLINE.

3 Control Register part
 These are register that controls between PCI bus or the USB and the serial communications block.
 When it is used in the Windows device driver environment, this Control Register need not be considered.

- INITIAL PORT ----- This is a port to initialize for the master and all slave units.
- STATUS PORT ----- This is a port to read the status of master.
- REQUEST PORT ----- This is a port that demands the function to make the master or the slave unit execute it.
- ANSWER BACK PORT --- This is a port to read the response data from master or the slave unit.

4 Serial interface control block
 This department is control block for AL- serial communication.
 The AL- serial communications interface department is internally insulated with the PC power supply.

5 Memory
 The initial data of each slave unit by the application software for initialization is stored on the memory in master.
 When the Initial-data-transfer-function is executed, master automatically sets the initial data to each slave unit.

1-5. Externals of product

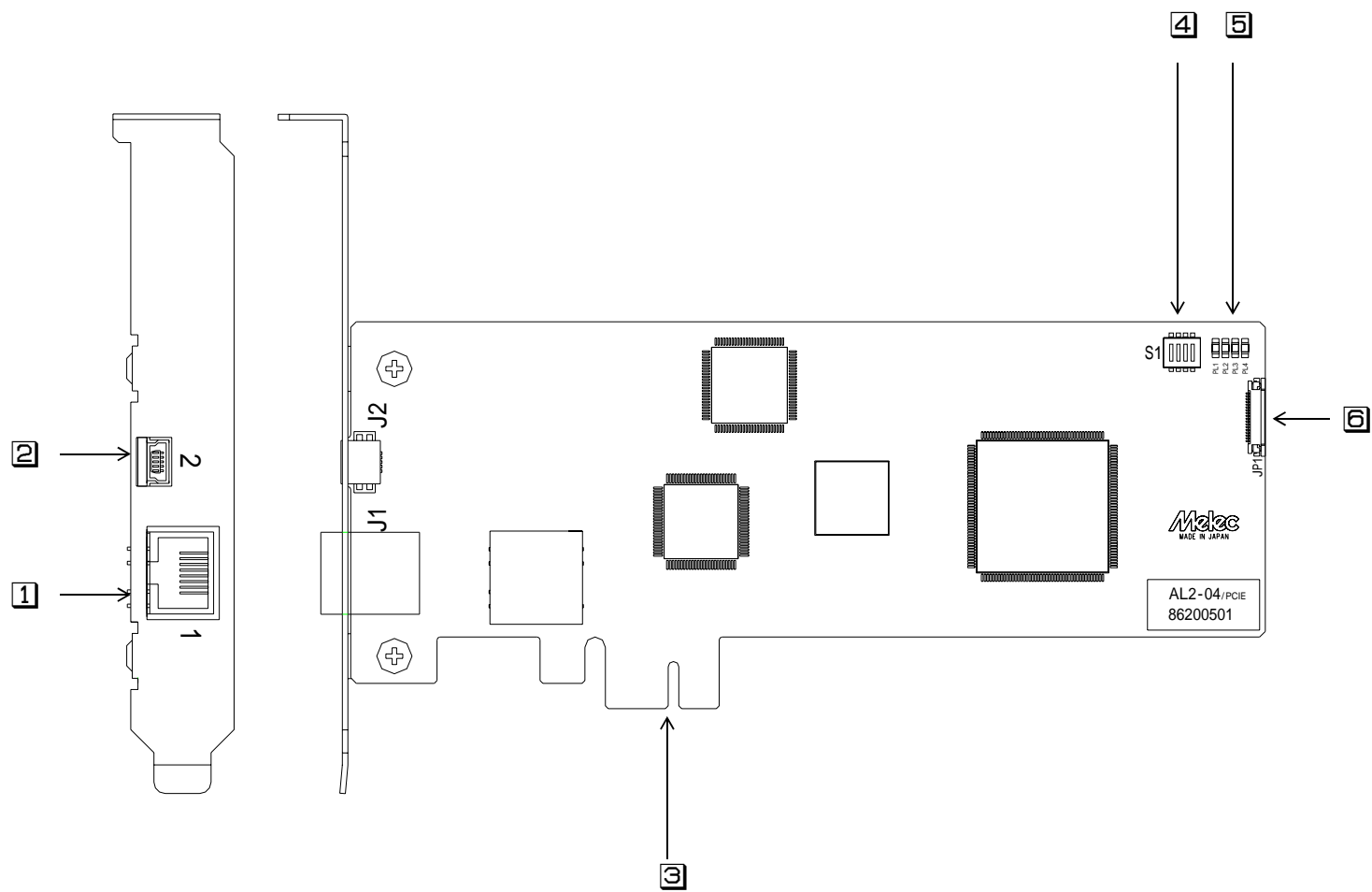

- ① J1 ----- This is a shield connector of the RJ-45 type to connect with the slave unit of the AL- series.
The terminator of the AL- communication is installing in this master by fixation.
- ② J2 ----- This is USB connector to connect with the PC at OFFLINE. (mini B type)
- ③ CN1 ----- This is a board edge connector to insert in the slot of PCI Express (x1 Lane).
- ④ S1 ----- This is a dip switch to set for PCI to be able to recognize the board number.
This switch number must set for it not to overlap when two master are installed in PC.
- ⑤ PL1, PL2 ----- These are LED for the monitor.
 - PL1 (Red) ... This LED lights when master detected abnormality of hard or abnormality of the AL- communication. This display is maintained even if it switches to OFFLINE.
 - PL2 (Green) ... This LED lights when the access from online (PCI bus) is possible.
This LED is turned off when there is a control right on the OFFLINE (USB) side.
 - PL3, PL4 ... It is unused.
- ⑥ JP1 ----- This is a connector for adjustment of the main unit.
Do not connect anything.

2 . Specifications

2-1. General specifications

| No. | Item | Specifications |
|-----|--|--|
| 1 | Supply voltage | DC +3.3 V \pm 9 % |
| 2 | Power consumption | 1.2 A or less |
| 3 | Operating ambient temperature and humidity | <ul style="list-style-type: none"> • 0 ~ + 45 • 80 % RH or less (without dew condensation) |
| 4 | Storage temperature and humidity | <ul style="list-style-type: none"> • 0 ~ + 55 • 80 % RH or less (without dew condensation) |
| 5 | Installation environment | <ul style="list-style-type: none"> • Inside a well-ventilated cabinet installed indoor, free from direct sunlight. • Not exposed to corrosive and flammable gasses, and not affected by oil mist, dust, salt, iron powder, water, and chemicals. • Not subject to constant vibration or excessive shock. • Not affected by electromagnetic noise caused by power equipment. • Free of radioactive materials and magnetic fields, and not in vacuum. |
| 6 | Dimensions | 164.55 (It thickness of attachment lug is included.) \times 68.9 \times 16.6 (mm) (PCI Express CEM standard x1, Standard height, half length card size.) |
| 7 | Weight | Approx. 0.1 kg |

2-2. PCI specifications

| No. | Item | Specifications |
|-----|------------------------------|--|
| 1 | Conforming standard | PCI Express Base Specification Rev1.0a |
| 2 | Bus interface | PCI Express x1 Lane |
| 3 | Interrupt | Unused |
| 4 | System resource | I/O area: 4k bytes |
| 5 | Number that can be installed | Two pieces |

2-3. Communication specifications

| No. | Item | Specifications |
|-----|---------------|--|
| 1 | AL- interface | <ul style="list-style-type: none"> • Conformity standard : RS485 (Insulation type) • Transmission protocol : Protocol for AL- communication • Slave connection number : 1 ~ 15 slave (slave address setting range: H' 1 ~ H' F) • Wiring distance/baud rate : 100 m (10 Mbps) / 50 m (20 Mbps) |
| 2 | USB interface | <ul style="list-style-type: none"> • Conformity standard : USB2.0 • Baud rate : FULL SPEED (12 Mbps) • Wiring distance : 5 m or less • USB connector : mini B |

2-4. Master specifications

| No. | Item | Specifications |
|-----|-------------------------------------|---|
| 1 | Connected confirmation of slave | <ul style="list-style-type: none"> Reading of slave information The slave type connected now can be read. |
| 2 | Error detection of AL-communication | <ul style="list-style-type: none"> Reading of error total number The error total number detected in the AL- communication after the power supply is turned on can be read. It is possible to use it for the evaluation of the communication environment. When retrying is detected, it counts as an error. The error total number can be counted 65535 times or less. More than it do not update a count. Clear of error total number The value in which the error total number is counted can be cleared to 0. Retry It is a function to evade the stagnation of the entire system by retrying it when the influence of the noise etc. is given to AL- communications. The number of retrying is set by an Environment-set-function. When retrying is made effective and the communication abnormality is detected, retrying is automatically executed. The setting of retrying is possible by the range from 0 (non-retry) to 3. |
| 3 | Initialize | <ul style="list-style-type: none"> Auto transmission of initialization The master carries out initialization for all slaves automatically when user carries out an Environment-set-function to a master. Interlock When an Environment-set-function is executed from the application, master executes initialization (a request) to each slave. The slave product of the AL- series doesn't accept other requests until the initial-request sent from master is received after the power supply is turned on. When other requests are received, an initial error is returned. As a result, master notifies the application the answer back. When the internal logic on the slave side was reset by the power failure etc. momentarily, operation by the improper data can be stopped. Please execute to master an Environment-set-function, after turning on slave's power supply. |
| 4 | Backup | <ul style="list-style-type: none"> The backup can easily edit the parameter of each slave from USB by initialization editing software by the OFFLINE, and a master can back up the edited parameter (Initial data). The initial data which a master backs up transmit a message for each slave at the time of the practice of the Initial-data-transmission-function automatically. |
| 5 | ONLINE/OFFLINE Function | <ul style="list-style-type: none"> As for the master board, access are possible from ONLINE (PCI Express) and OFFLINE (USB). The OFFLINE is a adjustment tool to offer the application that the function used USB to enable machine adjustment without the application program development of the user immediately for. |

* ONLINE and OFFLINE cannot be controlled at the same time.

Execute it after stopping the application from ONLINE when you control from OFFLINE.

* Please refer to each slave unit manual about the specification of the slave unit executed by master.

2-5. Input and output signal table
(1) Serial communication connector(J1)

1 2 3 4 5 6 7 8

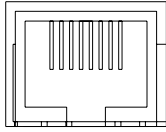

Connector :RJ-45(Shield type)
Recommended cable :KB-STP- L : length (~ 30 m or less)
(Made by Sanwa Supply: It is not an accessory.)

| No. | Direction | Signal name | Description |
|-----|-----------|-------------|--|
| 1 | - | N.C | Connection is prohibited. |
| 2 | - | N.C | Connection is prohibited. |
| 3 | I/O | +AL | + side input/output signal of the serial data(line driver positive logic) |
| 4 | I | +V | Power supply for AL- communication (+6 V) |
| 5 | I | -V | GND for AL- communication (0 V) |
| 6 | I/O | -AL | - side input/output signal of the serial data (line driver negative logic) |
| 7 | - | N.C | Connection is prohibited. |
| 8 | - | N.C | Connection is prohibited. |

(2) USB communication connector(J2)

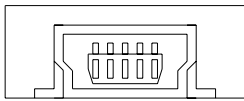

1 2 3 4 5

Connector : mini B type
Recommendation cable: KU-AMB5 : length (~ 5 m or less)
(Made by Sanwa Supply: It is not an accessory.)

| No. | Direction | Signal name | Description |
|-----|-----------|-------------|---|
| 1 | - | VCC | USB bus power supply |
| 2 | I/O | -DATA | - side input/output signal of USB communication |
| 3 | I/O | +DATA | + side input/output signal of USB communication |
| 4 | - | N.C | Connection is prohibited. |
| 5 | - | S.G | GND of USB communication |

Reference

For more information about a cable preparing in the AL- series and a recommended cable, refer to the instruction manual of "connection / others" .

2-6. Outside dimensions

General tolerance ± 0.5 mm or less
 Externals tolerance ± 1 mm or less

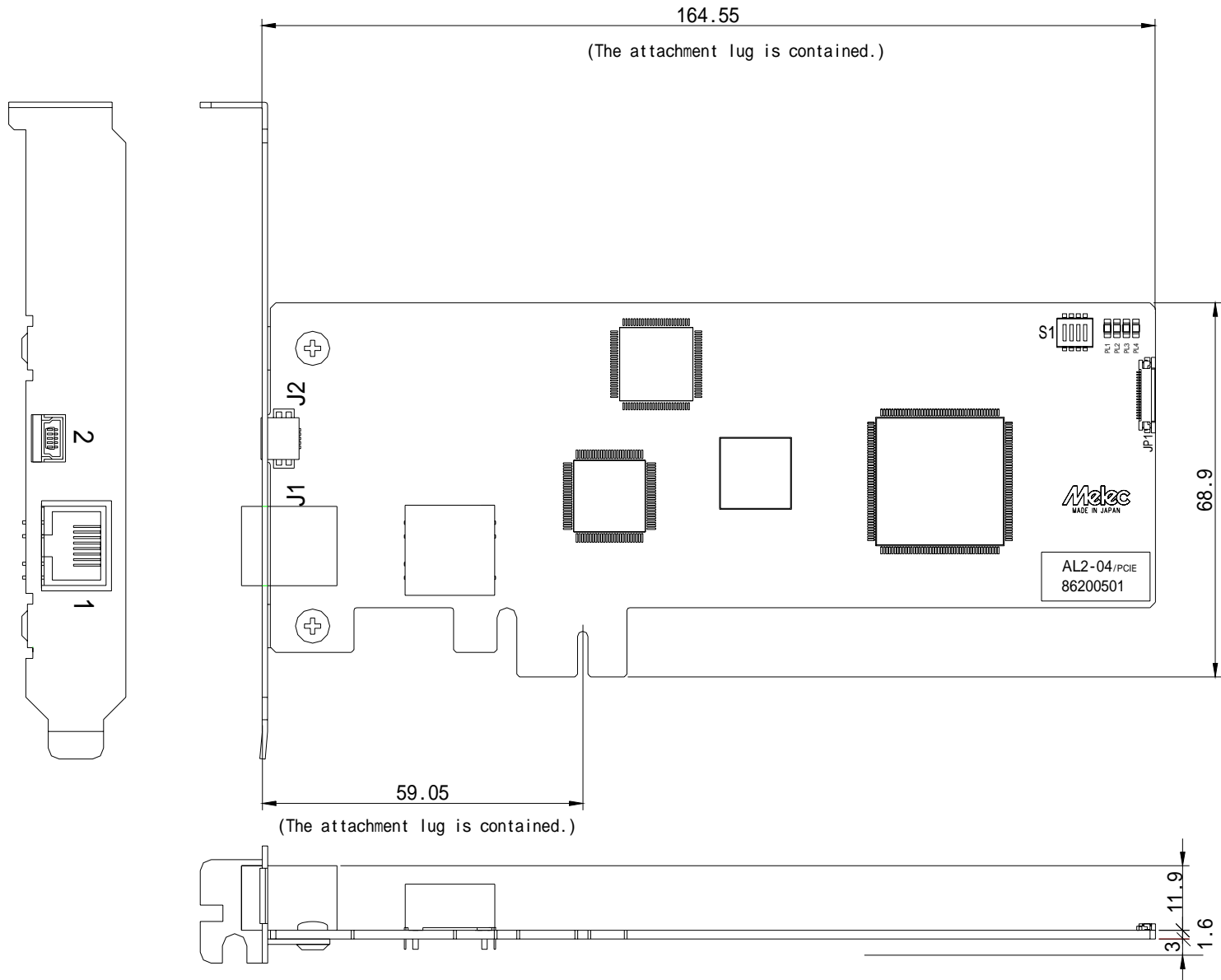

3 . Setting

3-1. Setting of board number (S1)

Before integrating the AL2-04/PCIE into the PC, set the switch(S1).

(By default (When the shipment from the factory), the dip switch is board number 0.)

When the AL2-04/PCIE are used at one more, assign board numbers such a way that no numbers are duplicated.

The following figure shows an example in which board number 1 is assigned.

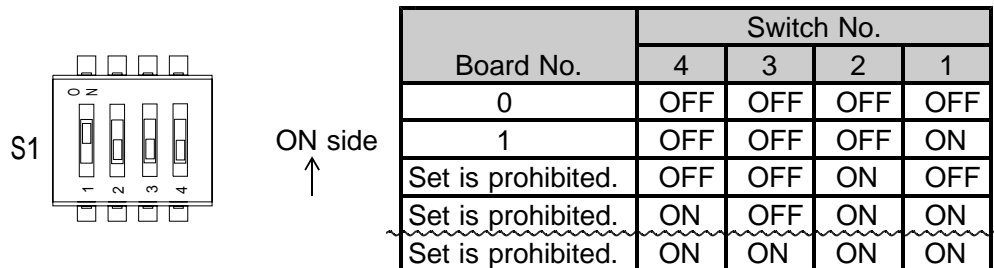

- When turning on power, the setting of dip switch(S1) becomes effective.
Set switch while turning off the power supply.
And, turn on the power supply after the setting change.

3-2. Setting of AL- communication

AL2-04/PCIE does the following setting of AL- communications by executing Environment-set-function unlike the switch setting done with other slave units.

(1) Address setting of the AL- series

The master address is H' 0 fixation.

And, please set not to overlap the address of each slave unit.

(2) Baud rate setting of the AL- series

As for the AL- communication baud rate, 10 Mbps/100 m or 20 Mbps/50 m can be selected.

To transmission rate to set in AL2-04/PCIE, please set the transmission rate of all slave units connected on AL-communication.

(3) Retry number setting of the AL- series

The setting of retrying is possible by the range from 0 (non retry) to 3.

The address of the slave unit, the transmission rate setting become effective at the time of power supply injection.

Please turn on the power supply again without fail.

And to the master execute an Environment-set-function after these setting changes.

Please refer to the device driver manual for Windows for details of function specification.

3-3. Setting of Extend Communication

When the Extend-unit is used, the address setting of the Extend-unit and the hard setting of the baud rate setting etc. are unnecessary.

The Extend-unit is controlled by an Extend-unit-communication-set-function and an Extend-unit-communication-control-function.

Please refer to the details of function specifications at a device driver instruction manual for Windows.

4 . Connection

4-1. Connection of AL- communication system

| | |
|--|--|
|  CAUTION | <p>Operation not anticipated may cause damage of the machine and the product.</p> <p>To prevent the malfunction by the noise, the AL- communications cable recommends recommended cable.</p> |
|--|--|

(1) Core connection of AL- communications cable

Please install the core in the master side. And, the personal computer system including the AL - communication is made to operated with stability.

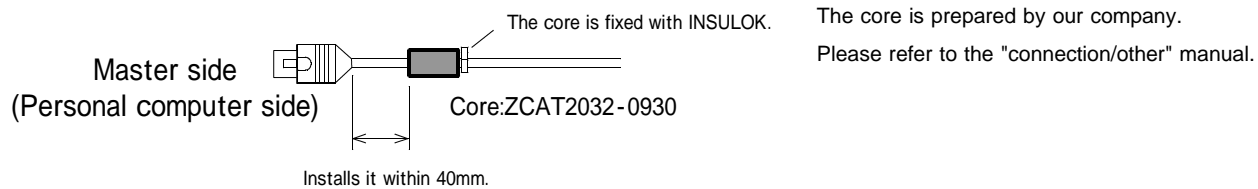

(2) Connection of terminator

AL2-04/PCIE mounts the terminator of the AL- communication, is connected, and the setting is unnecessary. It is necessary to install AL2-04/PCIE to the AL- communication network edge.

Connect terminator (CB-54/R) with the slave unit arranged on the AL- communication network edge. Do not connect the terminator with other equipment.

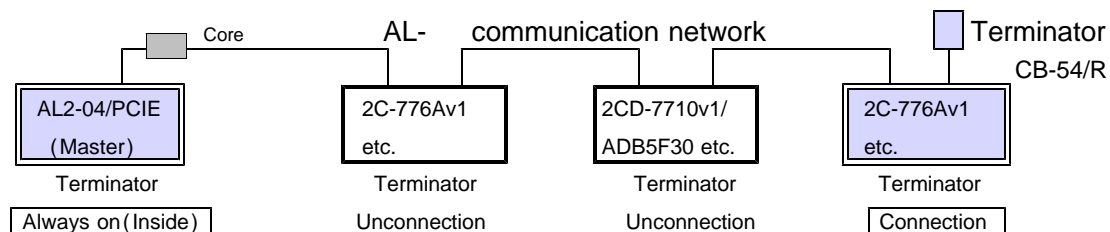

(3) Wiring distance of AL- communication

The total wiring distance of the AL- communications cable is the following range including the multidrop wiring.

- The wiring distance of Extend I/O doesn't relate to AL- communication baud rate (RATE).
- The wiring distance of Extend I/O from each slave is within 1 m.

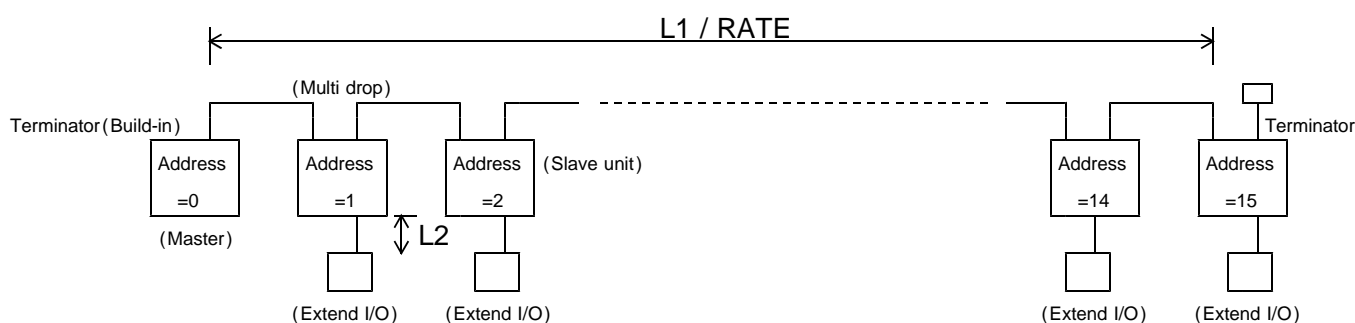

AL- communication baud rate and wiring distance

| Wiring distance | RATE | |
|-------------------------------|---------------|--------------|
| | 10 Mbps | 20 Mbps |
| L1 (AL- communication) | 100 m or less | 50 m or less |
| L2 (Extend I/O communication) | 1 m or less | |

The number of slaves that can be connected directly with the AL- communication are 15 units or less. Extend I/O that can be extended directly from the slave unit is not included in the number of slaves.

(4) Power supply and slave power supply for communication

The AL- communication power supply of each slave unit is supplied from the AL- master through the communications cable so that the entire AL- communication network should not become unstable when the power supply on each slave unit side is intercepted.

The reconnection of communications can be done by executing Environment-Function to the master when the power supply of the main unit on the slave side is obstructed.

5 . OFFLINE

As for AL2-04/PCIE, the access from ONLINE (PCI Express) and OFFLINE (USB port) is possible. Confirming the operation of each axis of each slave unit and the I/O signal can do immediately without the user program by the OFFLINE (USB) application software that our company offers.

- * ONLINE and OFFLINE cannot be controlled at the same time.
 Execute it after stopping the application from ONLINE when you control from OFFLINE.

5-1. Support environment of OFFLINE

| | |
|-----------------------------|---|
| Item | MAP-19-01vx.xx (Initial data edit software for AL- series) |
| Support OS | <ul style="list-style-type: none"> • Microsoft Windows 7 (32 bit version) • Microsoft Windows Vista (x86 version) • Microsoft Windows XP (32 bit version) • Microsoft Windows 2000 Professional SP4 |
| Support model | <ul style="list-style-type: none"> • IBM PC/AT Compatible • DOS/V |
| Communication specification | <ul style="list-style-type: none"> • USB 2.0 (FULL SPEED: 12 Mbps) • mini B type |

- * The exclusive use USB driver is necessary to operation from OFFLINE with USB.
 Install the USB driver attached to device driver MPL-34-01vx.xx/AL2W32 or MPL-35-01vx.xx/AL2W64 for Windows of AL2-04/PCIE beforehand.
- * Please download initial data edit software MAP-19-01vx.xx being offered from our homepage to the application software for OFFLINE.
- * Version No. ... Please confirm the latest version of vx.xx at the manual of the device driver, and MAP-19-01 application.

5-2. OFFLINE specification

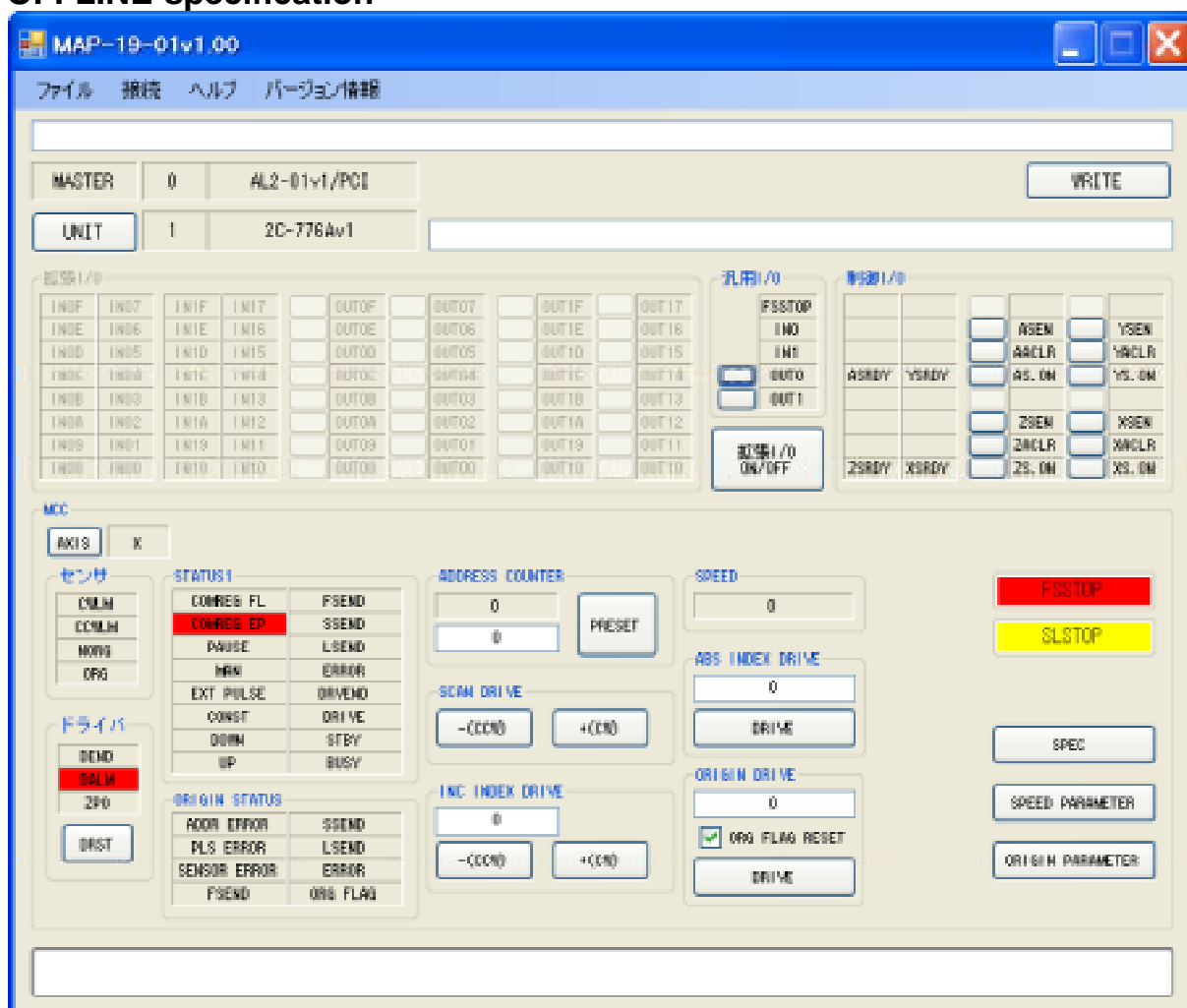

The backup data of master

- The data of the specified file can be written to master.
- It is possible to read out data from the master.
 Moreover, data can be preserved by .AL2DAT(TEXT) file format.
- Data can be printed.

The connection status of the slave unit connected with master can be confirmed.

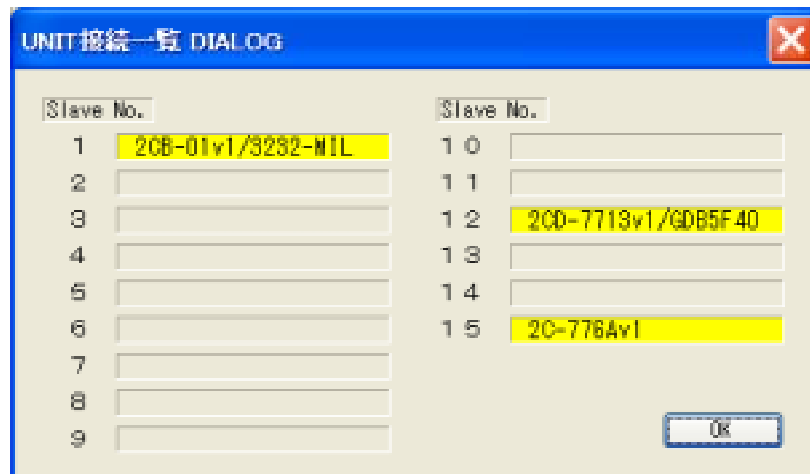

When the unit-number is specified, general-purpose I/O and Control I/O of the unit input is displayed. Moreover, the level of the output can be reversed by clicking general-purpose I/O and Control I/O output button.

After the unit-number is specified, the communication of Extend I/O unit can be turned on and off with the ON/OFF button of Extend I/O unit.

- When Extend I/O communication is turned on, Extend I/O input status is displayed.
- The level of the output can be reversed by clicking Extend I/O output button.

When the Extend communication is turned off with the output turned on, the output maintains the current state.

The following can be displayed by specifying the unit and the axis.

- STATUS1 PORT of each axis of unit.
- Value of ADDRESS COUNTER.
- Present speed under output.
- Status of input of sensor.

Each data of specified SPEC INITIALIZE of the axis, SPEED PARAMETER, and ORIGIN PARAMETER is displayed as the data that a present master stores.

It is possible to set it directly to master with each button of SPEC INITIALIZE, SPEED PARAMETER and ORIGIN PARAMETER as backup data of the specified axis.





The axis of the specified unit can execute each drive by clicking each button of ORIGIN DRIVE, SCAN DRIVE, INC INDEX DRIVE, and ABS INDEX DRIVE.

Moreover, the address counter is preset an arbitrary value.

The drive can be stopped with the FSSTOP button (immediate stop) or the SLSTOP button (deceleration stop) while executing the drive.

6 . Maintenance

| | |
|--|--|
|  CAUTION | <p>Incorrect handling may lead to an electric shock.</p> <p>Inspection and maintenance need to be conducted by an expert engineer only. Before inspecting and maintaining this product, turn off the power.</p> |
|--|--|

| | |
|--|---|
|  CAUTION | <p>An electric shock, injuries, and fire may be caused.</p> <p>Do not make repair and modification such as product disassembly and parts replacement.</p> |
|--|---|

6-1. Maintenance and inspection

(1) Cleaning method

To use the product in a favorable condition, conduct cyclic cleaning as follows.

- During the cleaning of the connector terminal plating part, wipe it with a dry, soft cloth.
- If stain is not removed by the dry wiping, soak a cloth in a solution in which neutral detergent is diluted, wring it out, and wipe off the stain with it.
- Do not use a high-volatile solvent such as benzene and thinner, and a wipe.
 This may deteriorate gold plating by transformation and oxidation.

(2) Inspection method

To use the product in a favorable condition, conduct periodic inspection.

Usually conduct the inspection every six months or every year.

To use the product in an extremely hot and humid or dusty environment, shorten the inspection interval.

| Inspection item | Inspection details | Criteria | Inspection method |
|--------------------|--|--|-------------------|
| Environment state | Check whether ambient and intra-device temperatures are appropriate. | 0 ~ + 45 | Thermometer |
| | Check whether ambient and intra-device humidities are appropriate. | 10 % ~ 80 % RH (without dew condensation) | Hygrometer |
| | Check whether dust is deposited. | No dust | Visual check |
| Installation state | Check whether the product is firmly secured. | Not loose (6 kg·cm) | Torque wrench |
| | Check whether connectors are completely inserted. | Not loose and removed | Visual check |
| | Check whether cables are to be removed. | Not loose and removed | Visual check |
| | Check whether connecting cables are to be broken. | Appearance is normal. | Visual check |

(3) Replacement method

If the product becomes faulty, repair it immediately because the entire device system may be affected.

To make the repair smoothly, a spare product should be prepared.

- To prevent an accident such as an electric shock during replacement, stop the device and turn off the power.
- If poor contacting is assumed, wipe contacts with a clean cotton cloth that is wet with industrial alcohol.
- Take a record of switch settings during replacement and return them to their state before the replacement.
- After the replacement, confirm that the new product is normal.
- For the faulty product replaced, have it repaired by returning it to the company with a report indicating as much details on the failure as possible.

6-2. Saving and disposal

(1) Saving method

Save the product in the following environment.

- Indoor (place in which the product is not in the path of direct sunlight.)
- Place at ambient temperature and humidity within the specifications.
- Place free of corrosive and inflammable gases.
- Place free of dust, dirt, salt, and iron powder.
- Place free of direct vibration and shock to the product body.
- Place free of water, oil, and chemicals droplets.
- Place where a person cannot ride or put objects on the product.

(2) Disposal method

Handle the product as industrial waste.

The main parts which revised by this manual

| Parts | Content |
|-------|---------|
| None | |

Technical Service

TEL.(042)664-5382 FAX.(042)666-5664
E-mail s-support@melec-inc.com

Sales and Service

TEL.(042)664-5384 FAX.(042)666-2031
URL:<http://www.melec-inc.com>

Melec Inc. Control equipment marketing department
516-10,Higashiasakawa-cho,Hachioji-shi,Tokyo 193-0834,Japan

This Operating Manual is subject to change without prior notice
for the purpose of product improvement.

C1210